

Absperrklappe PN 10/16 DN 200 – 1800 **AK322F-AA**
 aus Sphäroguss mit Flanschen
 doppelzentrisch

angewandte Normen:
 EN 558-1, EN 1092
 EN 593, PED 97/23 EG

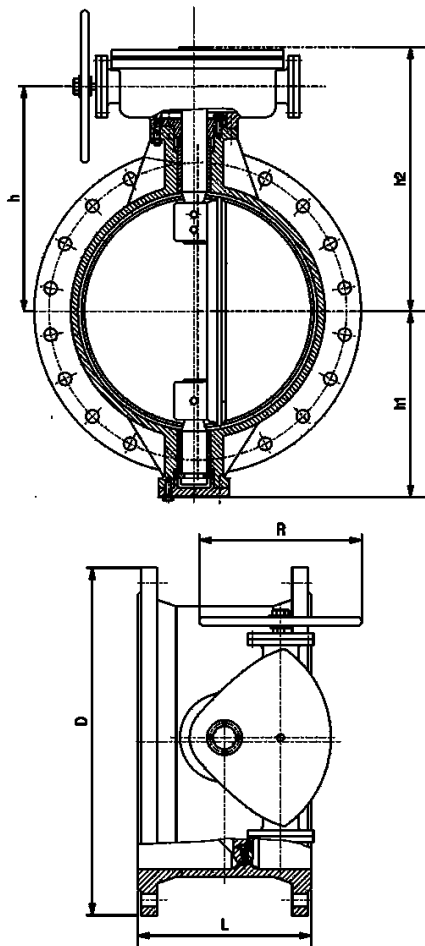

DN	Baumaße (mm)							Gewicht (kg)
	L <i>GR-14</i>	h	h1	h2	R	D (PN10)	D (PN16)	
200	230	272	210	315	250	340	340	71
250	250	375	240	385	250	395	405	92
300	270	466	291	500	320	445	460	150
350	290	491	320	525	320	505	520	186
400	310	433	345	550	320	565	580	228
450	330	458	385	560	320	615	640	285
500	350	537	445	680	500	670	715	415
600	390	597	515	745	500	780	840	566
700	430	632	525	807	640	895	910	730
800	470	750	655	937	640	1015	1025	1020
900	510	799	710	987	640	1115	1125	1350
1000	550	865	760	1052	640	1230	1255	1790
1100	590	765	810	1100	640	1340	1355	1920
1200	630	810	855	1142	640	1455	1485	2070
1400	710	983	975	1252	640	1675	1685	3600
1600	790	1280	1100	1392	640	1915	1930	4700
1800	870	1490	1280	1572	640	2115	2130	5600

4*			Dichtung	E* EPDM -40°C + 110°C	P* PTFE -30°C + 200°C	V* VITON -15°C + 210°C	Ersatzteil
3			Scheibe	EN-GJS-400-15 (GGG-40)			
2			Welle	X20Cr13			
1			Gehäuse	EN-GJS-400-15 (GGG-40)			(Epoxy)
Pos.	Menge	Einheit	Benennung	Norm - Kurzbezeichnung			Bemerkung
Erstellt / Geprüft			Vorgang		Änd.datum		 +49/391/52 08 93 74 armaturen@miranox.de www.miranox.de
Blatt	Rev.		Benennung		Ausg.datum		
1	0		AK322F(DN)AA*010 AK322F(DN)AA*016		2011-08-24		