

Zwischenflansch-

PN 10/16 DN 32 – 1200

**AK322Z-AA**

Absperrklappe aus Sphäroguss

**emmix WAFER**

weich dichtend

angewandte Normen:

Scheibe: Edelstahl

EN 558-1, EN 1092  
EN 593, PED 97/23 EG

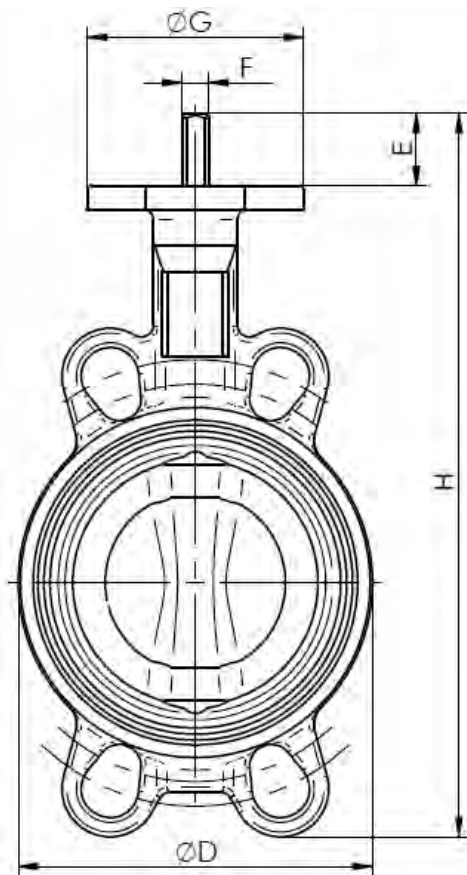

DN	Baumaße (mm)							Gewicht freie Welle (kg)
	BL GR-20	D	E	F*	G	H	ISO	
32	33	68	30	11	90	192,7	F07	1,5
40	33	76	30	11	90	196,0	F07	1,7
50	43	100	30	11	90	211,5	F07	2,0
65	46	108	30	11	90	234,0	F07	2,6
80	46	124	30	11	90	265,0	F07	3,1
100	52	147	30	11	90	301,0	F07	3,9
125	56	180	33	14	90	339,5	F07	6,1
150	56	206	33	14	90	359,0	F07	7,2
200	60	257	33	17	90	428,0	F07	11,0
250	68	324	23	22	130	515,5	F10	20,5
300	78	376	23	22	130	571,0	F10	29,5
350	78	430	31	22	160	632,5	F10	35,4
400	102	485	31	27	160	719,0	F12	54,6
450	114	536	38	36	190	758,5	F14	80,8
500	127	593	38	36	210	850,5	F14	113,3
600	154	690	80	60	210	1014,0	F16	170,5
700	165	830	106	65	300	1186,0	F25	290,9
800	190	902	106	80	300	1301,0	F25	363,3
900	203	1010	110	80	350	1415,0	F25	497,0
1000	216	1116	110	80	350	1555,0	F25	598,5
1200	254	1334	120	100	350	1813,0	F30	931,5

\* ab DN600: Welle mit Feder und Nut

4			Manschette	E* EPDM	N* NBR	V* VITON	S* SILIKON
				-40°C + 110°C	-10°C + 90°C	-15°C + 210°C	-60°C + 200°C
3			Scheibe	CF8M	(1.4408)		
2			Welle	AISI 420	(1.4104)		
1			Gehäuse	EN-GJS-400-15	(GGG-40)		(Epoxy)

Pos.	Menge	Einheit	Benennung	Norm – Kurzbezeichnung	Bemerkung
Erstellt / Geprüft			Vorgang		Änd.datum
Blatt	Rev.		Benennung		Ausg.datum
1	1		<b>AK322Z(DN)AA*010</b> <b>AK322Z(DN)AA*016</b>		2013-01-30

Änderungen vorbehalten – Abbildung kann abweichen  
Subject to change - the image may vary

Zwischenflansch- PN 10/16 DN 32 - 1200

**AK322Z-AA**

Absperrklappe aus Sphäroguss – WAFER

- **Anhang 1 -**

weich dichtend

**Betätigungen**

Scheibe: Edelstahl

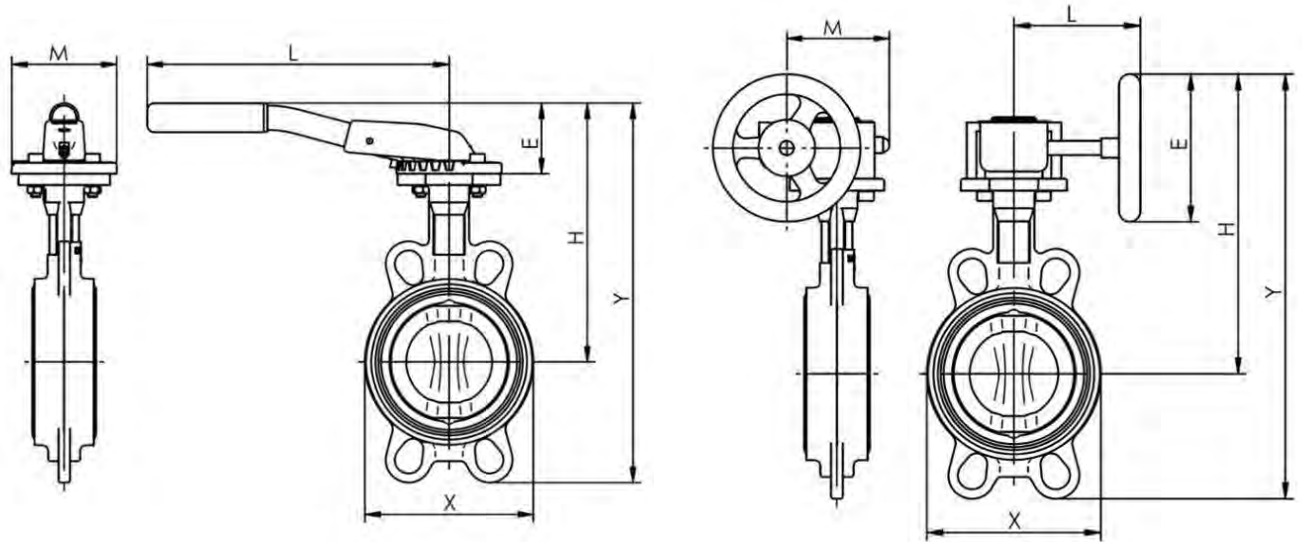

DN	Absperrklappe mit Handhebel						Absperrklappe mit Getriebe					
	M	L	E	H	Y	Gewicht	M	L	E	H	Y	Gewicht
32	90	220	49	151	212	1,9	88,0	128	125	190	251	2,7
40	90	220	49	159	215	2,1	88,0	128	125	198	254	2,9
50	90	220	49	169	230	2,9	88,0	128	125	208	269	3,7
65	90	220	49	184	253	3,0	88,0	128	125	223	292	3,8
80	90	260	60	201	295	3,6	88,0	128	125	229	323	4,3
100	90	260	60	225	331	4,4	88,0	128	125	253	359	5,1
125	90	315	75	255	381	6,6	88,0	135	160	283	409	7,5
150	90	315	75	268	401	7,6	88,0	135	160	295	428	8,6
200	90	315	75	300	470	11,6	106,0	152	200	355	525	13,6
250							128,0	222	250	442	652	24,0
300							128,0	222	250	468	708	33,0
350							128,0	222	250	498	761	39,0
400							141,5	278	300	572	880	63,5
450							188,0	321	400	630	970	99,2
500							188,0	321	400	682	1062	113,2
600							277,5	408	500	799	1239	205,0
700							277,5	408	500	895	1385	325,0
800							277,5	456	600	985	1550	404,0
900							360,0	510	700	1108	1718	557,0
1000							360,0	510	700	1183	1858	659,0
1200							360,0	579	700	1288	2106	998,0

Anderungen vorbehalten – Abbildung kann abweichen  
Subject to change – the image may vary

Erstellt / Geprüft		Vorgang		Änd.datum	
Blatt	Rev.	Benennung		Ausg.datum	
2	1	<b>AK322Z(DN)AA*010</b> <b>AK322Z(DN)AA*016</b>		2013-01-30	