

**Doppelflügel-Rückschlagklappe PN 16 DN 50 – 600 RK322D-AA**  
 aus Sphäroguss  
 metallisch dichtend

angewandte Normen:

EN558-1, EN 1092,  
 PED 97/23 EG

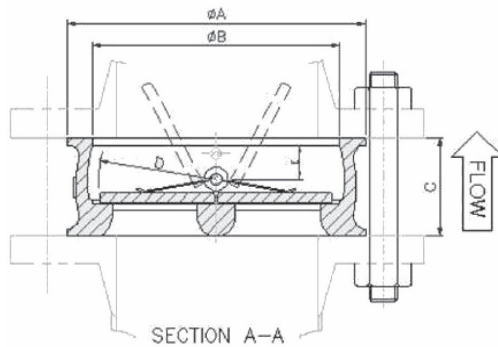
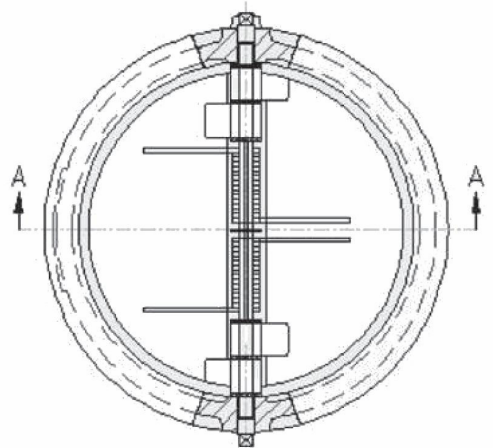

DN	Baumaße [mm]					Gewicht [kg]
	A	B	C	D	E	
50	107	70,5	43	28,8	19	1,5
65	127	80	46	36,1	20	2,4
80	142	94	64	43,4	28	3,6
100	162	117	64	52,8	27	5,7
125	192	145	70	65,7	30	7,3
150	218	170	76	78,6	31	9,0
200	273	221	89	104,4	33	17,0
250	328	275,5	114	127	50	26,0
300	383	325,5	114	148,3	43	42,0
350	444	360	127	172,4	45	55,0
400	495	410	140	197,4	52	75,0
450	555	467	152	217,8	58	101,0
500	617	515	152	241	58	111,0
600	734	624	178	295,4	73	172,0

4			Dichtung	metallisch	
3			Feder	1.4401	
2			Flügel	EN-GJS-400-15 (GGG-40)	
1			Gehäuse	EN-GJS-400-15 (GGG-40)	
Pos.	Menge	Einheit	Benennung	Norm – Kurzbezeichnung	Bemerkung
Erstellt / Geprüft			Vorgang	Änd.datum	 +49/391/52 08 93 74 armaturen@miranox.de www.miranox.de
Blatt	Rev.		Benennung	Ausg.datum	
1	0		<b>RK322D (DN) AA0016</b>	2011-02-12	