

Absperrventil
aus Grauguss mit Flanschen
Faltenbalg

PN 16 DN 15 – 300 AV311F-AC

angewandte Normen:

EN 558-1, EN 1092,
 PED 97/23 EG

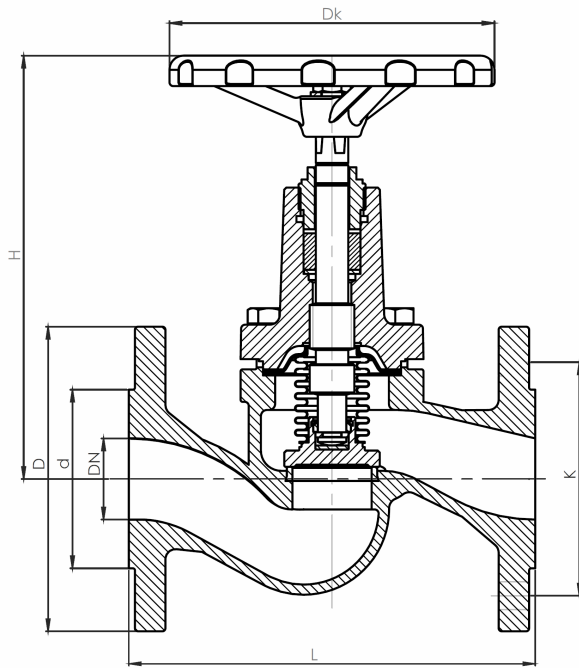

DN	Baumaße							Gewicht
	L	H	h	K	d	D	Dk	
15	130	178	5	65	46	95	125	3,2
20	150	178	5	75	56	105	125	3,9
25	160	193	7	85	65	115	125	4,6
32	180	201	8	100	76	140	125	6,5
40	200	224	10	110	84	150	150	9,0
50	230	228	13	125	99	165	150	11,0
65	290	270	17	145	118	185	175	15,8
80	310	295	20	160	132	200	200	20,5
100	350	321	25	180	156	220	250	35,0
125	400	388	32	210	184	250	300	49,0
150	480	448	38	240	211	285	400	76,0
200	600	575	50	295	266	340	500	130,5
250	730	645	63	355	319	405	500	210

6			Faltenbalg	X6CrNiMoTi-17-12-2	
5*			Deckeldichtung	Graphit + CrNi	Ersatzteil
4			Sitz	X12Cr13 (1.4006)	
3			Spindel	X20Cr13 (1.4021)	
2			Deckel	JL1040 (GG25/ 0.6025/ EN-GJL250)	
1			Gehäuse	JL1040 (GG25/ 0.6025/ EN-GJL250)	
Pos.	Menge	Einheit	Benennung	Norm – Kurzbezeichnung	Bemerkung
Erstellt / Geprüft			Vorgang	Änd.datum	 +49/391/52 08 93 74 armaturen@miranox.de www.miranox.de
Blatt	Rev.		Benennung	Ausg.datum	
1	0		AV311F (DN) AC0016	2011-02-12	